

XEN-NCM9924 mounted in PGA-68

Sander van Herwaarden

1	Introduction	2
1.1	About This Application Note	2
2	Short Description	2
2.1	Applications	3
3	Technical Data	4
3.1	Specifications	4
3.2	Sensor Photo's And Packaging Information.....	5
4	Extended Description And General Notes On Use	8
4.1	Nanocalorimeter Operation Principle	8
4.2	Types Of Calorimeter Chips	8
4.3	Description Of The Sensors	9
5	References	11

1 Introduction

1.1 About this Application Note

This Application Note is intended to help the users of Xensor-Integration NanoCaloriMeters and interface electronics with the set-up and execution of their experiments. It will give some theoretical background information, practical guidelines, specific applications and references to the work of other users.

The Application Note is by no means exhaustive. This means, that if you miss something and have questions, or if you have useful information or interesting applications that you want to share, we highly appreciate your contribution to improving this note.

2 Short description

Introduction

There are two types of nanocalorimeter chips available from Xensor, those based on thicker monocrystalline silicon membranes and those based on thin silicon-nitride membranes.

The first types have low thermal isolation, but are very robust, they are well suited for use in liquid and slow applications (XEN-LCM2506, XEN-LCMquad, XEN-NCM9924).

The last type is fragile but very well isolated and fast, this is more suited for application in gaseous environments and for fast measurements, such as scanning calorimetry (XEN-TCG3880).

XEN-LCM2506

The XEN-LCM2506 is a thermopile-based calorimeter chip consisting of a 3.5×3.5 mm square membrane of monocrystalline silicon, approximately 4-8 μm thick (depending upon technology). The membrane is suspended in a 5×5 mm outer size silicon frame of 500 μm thick (the original thickness of the wafer and the membrane area before etching). In the membrane a thermopile of 160 p-type monocrystalline silicon versus aluminum couples is integrated, leaving a free area in the middle in which a heater is integrated for calibrating the transfer of the nanocalorimeter, see Fig. 2.1 & 2.2.

XEN-LCMquad

The XEN-LCMquad contains 4 chips of the same type as in the XEN-LCM2506 on a 10×10 mm die, see Fig. 2.3. Both XEN-LCM2506 and XEN-LCMquad are customarily mounted in a PGA-68 ceramic housing, with a hole to accommodate the silicon chip. The chip is mounted flush with the surface of the ceramic, this allows flow-injection analysis systems, in which liquid flows over the surface of the sensor.

XEN-NCM9924

Next to the XEN-LCM2506, the heavy-duty sensor XEN-NCM9924 is available. This sensor features a membrane of 22-45 μm thick, 8.3×8.3 mm large in a 10×10 mm frame, which gives a more robust sensor. It also has an integrated silicon-aluminum thermopile, but also has aluminum heaters, galvanically separating heater and thermopile, see Fig.2.4.

Because of the thickness of the membrane, only a low thermal resistance is achieved, which makes this sensor especially suited for liquid applications, where high thermal resistances are strongly decreased by the flowing liquids. The strong membrane makes this sensor suitable for repeated use with enzyme layers or other coatings, which can be removed without destroying the membrane. Also this sensor has the chip flush with the housing for flow-injection analysis applications.

But apart from liquid applications, applications in, for instance, electronic noses have also been reported [Lerchner et al, Par 4.1].

The sensor has also been used for more traditional calorimetric analysis, in which the epoxy glue between chip and housing has been replaced by highly-conductive silver glue, improving the thermal link between chip frame and housing. Then, fast calorimetric measurement can be carried out [Winter and Höhne, Par. 4.5].

Xensor Integration bv

Distributieweg 28
2645 EJ Delfgauw
The Netherlands

Phone +31 (0)15-2578040
Fax +31 (0)15-2578050
Email info@xensor.nl

Founded 18 May 1988

Trade reg. 27227437

Site www.xensor.nl

Smart Sensor Devices

ABN-AMRO 60 50 40 311

IBAN NL42ABNA0605040311

VAT NL 009122746 B01

XEN-TCG3880

The newest trend in calorimetric research is fast scanning calorimetry, in which heating rates and cooling rates are not measured in Kelvin/minute, but in kiloKelvin/second or even faster. For this, you want to have as little mass to heat and (more difficult) to cool, and thick membranes are less advantageous. The XEN-TCG3880 has been used extensively by Schick et al from the University of Rostock in fast calorimetry experiments with heating and cooling rates in excess of 10 kK/s. The XEN-TCG3880 features a thin-film membrane of low-stress silicon-nitride (SiN), with polysilicon thermopile and heater, in a 3.33×2.50 mm silicon frame. The thin (fragile) and thermally highly isolating membrane make this sensor less suitable for liquid applications. So, probably someone will try just that in the near future.

2.1 Applications

Applications

Below is a list of (known) applications of the calorimeter sensors. For more on applications see the overview article in *Thermochimica Acta* (2005) in Section 4.6, available on www.xensor.nl.

<i>application</i>	<i>sensors</i>	<i>references [chap. 4]</i>
Fast scanning calorimetry	XEN-LCM2506, XEN-LCMquad, XEN-NCM9924, XEN-TCG3880	Rostock, Inst. Analysentech.
Enzymatic blood analysis	XEN-LCM2506, XEN-LCMquad, XEN-NCM9924	Ciba, Freiberg
Electronic nose	XEN-LCM2506, XEN-LCMquad, XEN-NCM9924	Freiberg
Liquid calorimetry	XEN-LCM2506, XEN-LCMquad, XEN-NCM9924	Freiberg
Thermal analysis	XEN-LCM2506, XEN-LCMquad, XEN-NCM9924	Catalonia
Mixing reaction heat detection	XEN-LCM2506, XEN-NCM9924	

3 Technical data

3.1 Specifications

Table 2.1 Specifications (ambient temperature 22 °C)

	XEN-LCM 2506	XEN-LCM quad	XEN-NCM 9924	XEN-TCG 3880	unit	symbol	notes
Parameter	typ	typ	typ	typ			
Dimensions							
housing size	29x29x7	29x29x7	29x29x7	3.3x2.5x0.3	mm ³		
chip dimensions	5x5	4 of 5x5	10x10		mm ²		
membrane size	3.5x3.5	3.5x3.5	8.3x8.3		mm ²		
membrane thickness	4-8	4-8	22-45	1	µm		
Output							
in air at 1013 mbar	8	8	1.2-2.4	30	V/W		
in still water	4	4	-	-	V/W		
Time constant							
in air				9	ms	τ	
in vacuum				36	ms		
Stability							
short term				100	ppm		
long term				1000	ppm		
Thermopile							
resistance	150	150	50	55	kΩ	R _{tp}	
effective sensitivity				1.3	mV/K	S _{tp}	
intrinsic sensitivity	50-80	50-80	50	2.4	mV/K		
temp coefficient				0.05	%/K		
Heater							
resistance	0.8	0.8	0.44	0.6	kΩ	R _{heat}	
resistance R1-R2	-	-	1.0	-	kΩ	R _{heat}	Alu heater
resistance R1-R3	-	-	0.25	-	kΩ	R _{heat}	Alu heater
temperature coefficient				0.1	%/K		
Thermal resistance							
membrane				100	kK/W		
temperature coefficient					%/K		
membrane + gas				23	kK/W		
temperature coefficient				-0.08	%/K		
chip to housing					K/W		
Maximum heating voltage							
in air				2.5	V	U _{heat}	
in vacuum				1	V		
Sensor ambient temp							
minimum				-40	°C		
maximum				85	°C		
Heater max temp							
				250	°C		

3.2 Sensor photo's and packaging information

XEN-LCM2506: 68 pins 11x11 PGA cavity down

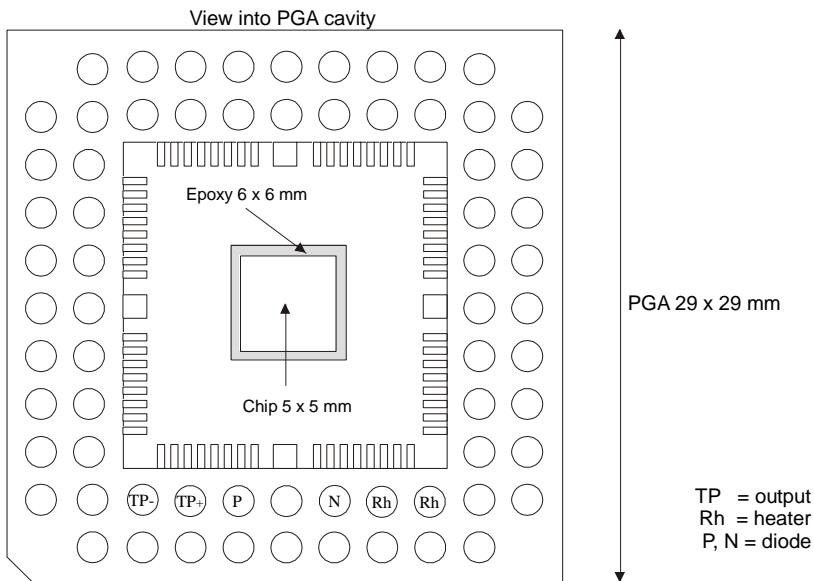

Figure 2.1 Liquid side of XEN-LCM2506

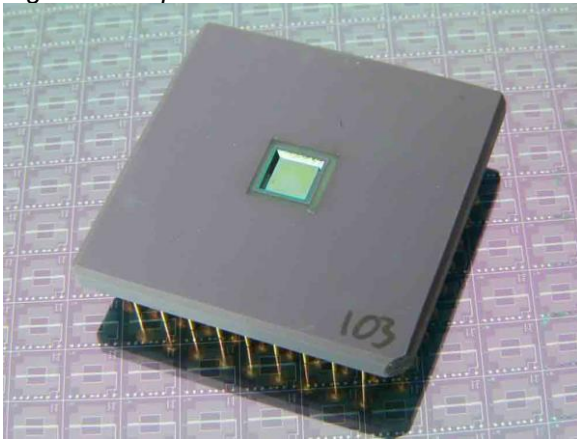
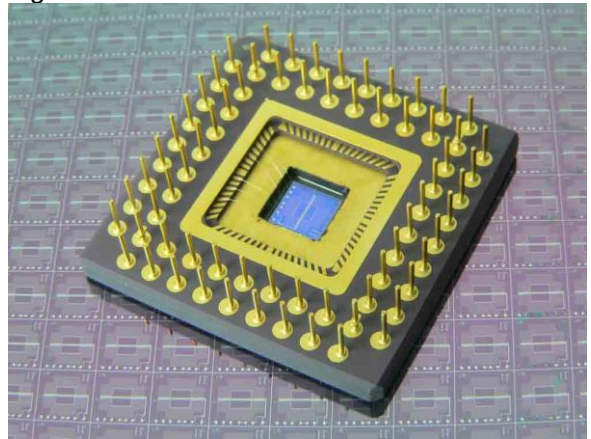

Figure 2.2 Electronics side of XEN-LCM2506



XEN-LCMquad: 68 pins 11x11 PGA cavity down

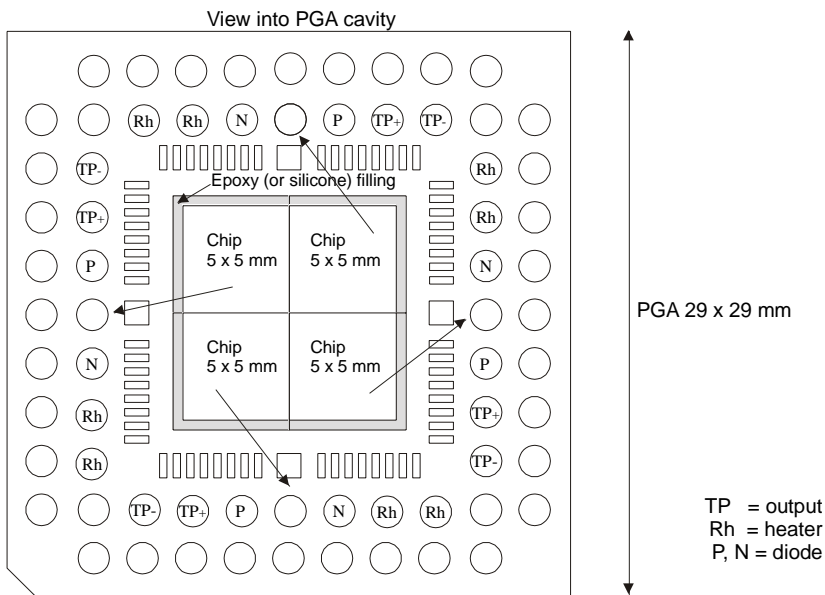
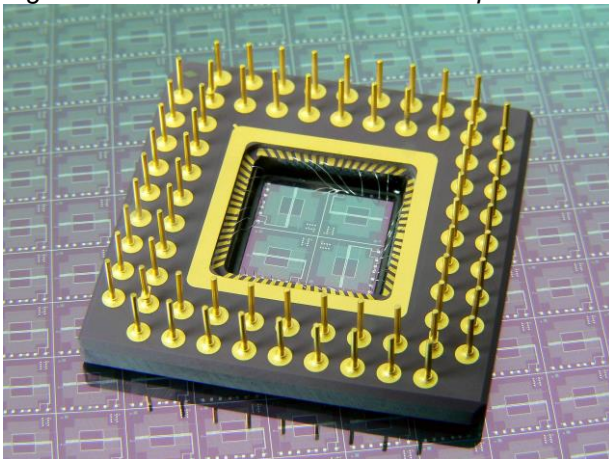

Figure 2.3 Electronics side of XEN-LCMquad



Xensor Integration bv

Distributieweg 28
2645 EJ Delfgauw
The Netherlands

Phone +31 (0)15-2578040
Fax +31 (0)15-2578050
Email info@xensor.nl

Founded 18 May 1988
Trade reg. 27227437
Site www.xensor.nl

Smart Sensor Devices

ABN-AMRO 60 50 40 311
IBAN NL42ABNA0605040311
VAT NL 009122746 B01

XEN-NCM9924: 68 pins 11x11 PGA cavity down

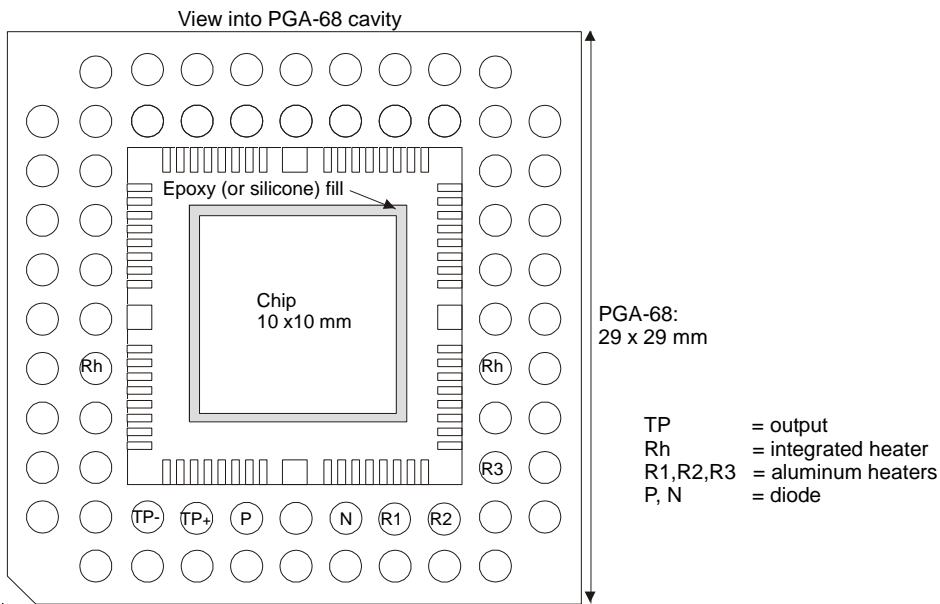
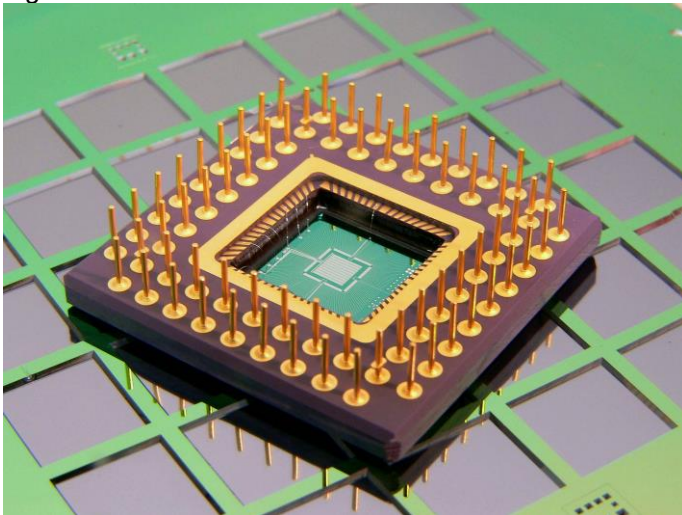

Figure 2.4 Electronics side of XEN-NCM9924



Xensor Integration bv

Distributieweg 28
2645 EJ Delfgauw
The Netherlands

Phone +31 (0)15-2578040
Fax +31 (0)15-2578050
Email info@xensor.nl

Founded 18 May 1988
Trade reg. 27227437
Site www.xensor.nl

Smart Sensor Devices

ABN-AMRO 60 50 40 311
IBAN NL42ABNA0605040311
VAT NL 009122746 B01

4 Extended description and general notes on use

4.1 Nanocalorimeter operation principle

Why calorimeter chips

Calorimetry is the science of the measurement of thermal properties of materials, or the measurement of heat released or absorbed during reactions or phase changes. In traditional calorimeter instruments, crucibles, miniature ovens and thermocouples are put together by fine machining and assembly to manufacture the thermal measurement environment. This leads to certain characteristics of these instruments, certain time constants and minimum amounts of sample to perform the measurement.

In some cases, the physics or circumstances of real life demand that analyses be performed faster, or that smaller sample masses be analyzed. For this, calorimeter chips have been developed, which combine the functions of crucible, oven and thermocouple in a single chip of silicon with integrated circuits in it. This makes the calorimeter much smaller and faster, which allows for the analyzing of smaller samples with greater speed.

Passive and active measurement

There exist two types of thermal measurement. In the passive type, such as measuring material properties, energy has to be supplied to the material, after which the changes in the material can be observed. In the active type, such as measuring chemical reactions, the chemical reaction supplies the energy for the measurement, and this measurement can be carried out without any biasing.

Calorimeter chips integrate the functions to carry out both types of measurements. A typical calorimeter chip consists of a thin membrane, suspended in a (0.5 mm) thick frame (the rim) of silicon. A thermopile integrated in or on top of the membrane measures the temperature increase of the center of the membrane with respect to the frame, and heaters in and around the center of the membrane are used to create the desired temperature (increase) in the center of the membrane, compared to the frame.

In general, calorimeter chips (or nanocalorimeter chips to indicate the minute amounts of heat and sample that can be measured) are used within a static isothermal environment.

For a passive measurement, the middle of the membrane, the active area, is varied in temperature – as measured with the thermopile- with the heaters to bring samples on the active area to the desired temperature, or to subject samples to a specific temperature profile (in a predetermined rate of temperature change), to observe the behavior of the sample with temperature (changes). Two main techniques exist. The simple one biases with a steadily rising amount of power, and measures the temperature profile. When a sample absorbs heat due to melting or another phase change, the temperature will lag behind, and this lag is a measure of the amount of heat absorbed. The more accurate one uses feedback, and maintains a certain temperature profile by supplying the needed amount of power. Now, when the sample absorbs heat, this is seen as a temporary rise in the power needed to achieve the desired temperature profile. The excess energy supplied is now the direct amount of energy absorbed by the sample. This method is more accurate and direct, but more difficult to implement.

For an active measurement the output voltage of the thermopile is simply measured to give data on the heat output of the process. The heaters can now be used to advantage for a first order calibration of the transfer of the device, i.e., the output voltage obtained for a certain power supplied by the reaction. In general, corrections have to be made when the heating pattern by the reaction is not identical to that of the heating resistor. In that case, they will not give the same transfer in Volt/Watt. This especially applies to measurements in liquids and liquid flows. Prof. Torra from the Univ of Catalonia and Dr. Lerchner from the Freiberg Bergakademie (see References) have done a lot of work in this modeling.

4.2 Types of calorimeter chips

There exist various types of calorimeter chips. Xensor Integration offers two different types. The one type is made with monocrystalline silicon membranes of 4-45 μm thickness. The other type has silicon-nitride/oxide membranes of in total about 1 μm thickness.

Xensor Integration bv

Distributieweg 28
2645 EJ Delfgauw
The Netherlands

Phone +31 (0)15-2578040
Fax +31 (0)15-2578050
Email info@xensor.nl

Founded 18 May 1988

Trade reg. 27227437

Site www.xensor.nl

Smart Sensor Devices

ABN-AMRO 60 50 40 311

IBAN NL42ABNA0605040311

VAT NL 009122746 B01

The silicon membrane chips are characterized by a low thermal resistance, a robust membrane, high sensitivity of the thermopile and lower time constant. And the membranes are generally fairly large, 4-8 mm in lateral size. They are especially well suited for use in liquids, since the liquid environment requires robust membranes that will not break when slight pressure or pressure shocks are present. Moreover, the liquid, especially in a flow-through analysis, strongly decreases the thermal resistance between center and edge of the membrane, even for the silicon membranes that already show a low thermal resistance. There is no advantage in using thin fragile membranes with higher thermal resistance. Measurements in liquids are usually performed in a constant temperature environment. The temperature range in which these sensors are operational is typically between -30 °C and 100 °C.

The silicon-nitride membrane chips are characterized by a high thermal resistance to the ambient, a very small time constant and fragile membranes. This makes these sensors particularly suited for measurements in gaseous environments on small samples with high temperature scanning rates. Temperature scan rates of up to 10 kK/sec have been obtained by Prof. Schick at Rostock University (see References), where traditional calorimetry instruments stop at 1 K/sec, or 10 K/sec for advanced models. Thus, in some tens of milliseconds, a complete measurement is carried out. Here typical temperature ranges are from 20 K up to 450 K for the frame, while the membrane center, with the sample, can go up to 800 K for very short periods of time. Thus, the range of these sensors comes closer to that of basic calorimeter instruments.

4.3 Description of the sensors

XEN-LCM2506

The liquid nano calorimeter XEN-LCM2506 consists of a thin mono-crystalline silicon membrane in a thick silicon rim. The sensitive area in the middle of the membrane contains a heater resistor. Between the heater and the rim, a silicon-aluminum thermopile is integrated in the membrane to measure temperature increase of the sensitive center with respect to the rim. The rim serves as mechanical suspension and as thermal reference.

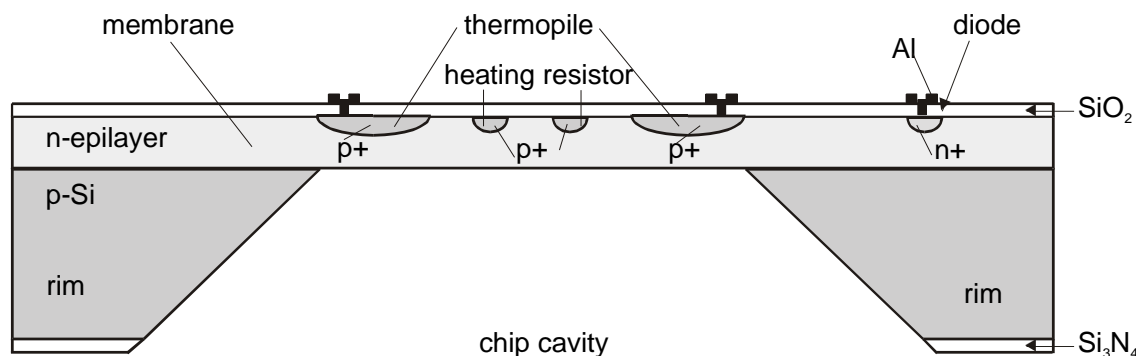

In this way, *heat of reaction* generated by a catalytic layer in the center of the membrane *can be measured* with the thermopile (*TP+* and *TP-*, see connection diagram) and the sensor's sensitivity can be calibrated using the heater (*Rh*, 2 leads).

The *thermal characteristics* of thin deposited layers (such as thermal conductivity and specific heat) *can be measured* using the heater as actuator and measuring the change in thermal properties of the sensor due to the deposited thin layer.

An integrated diode temperature sensor is added on the non-sensitive part of the sensor which allows monitoring of the ambient temperature (indicated as *P* and *N*).

The sensor is offered with a *blank sensitive area*, on which catalytic, enzymatic or biomedically active layers can be deposited for testing.

The sensor chip is encapsulated in a ceramic Pin-Grid Array (PGA), a 68 pins 11x11 PGA cavity down, with a 6x6 mm square hole in the bottom where the sensor backside is exposed to the liquid. Because of the closed membrane, a perfect separation between liquid and electronics side is obtained while

Xensor Integration bv

Distributieweg 28
2645 EJ Delfgauw
The Netherlands

Phone +31 (0)15-2578040
Fax +31 (0)15-2578050
Email info@xensor.nl

Founded 18 May 1988

Trade reg. 27227437

Site www.xensor.nl

Smart Sensor Devices

ABN-AMRO 60 50 40 311
IBAN NL42ABNA0605040311
VAT NL 009122746 B01

maintaining high sensitivity. This is especially convenient for use with flow-injection analysis systems or other liquid systems.

XEN-LCMquad

The XEN-LCMquad has 4 nanocalorimeter chips of the XEN-LCM2506 in a single PGA-housing. The sensor chip is *encapsulated* in a ceramic Pin-Grid Array (PGA), a 68 pins 11x11 PGA cavity down, with a 11x11 mm square hole in the bottom where the sensor backside is exposed to the liquid. Because of the closed membrane, a perfect separation between liquid and electronics side is obtained while maintaining high sensitivity. This is especially convenient for use with flow-injection analysis systems or other liquid systems.

XEN-NCM9924

The nano calorimeter XEN-NCM9924 consists of a 22-45 μm thick, 8.3 x 8.3 mm large mono-crystalline silicon membrane in a thick silicon rim.

The sensitive area in the middle of the membrane contains three *heater resistors*. Two heaters are made of aluminum, 260 Ohm and 800 Ohm, and galvanically isolated from the thermopile by a dielectric layer. The third is a diffused (p-type silicon) resistor heater of 440 Ohm integrated in the membrane, which is separated from the thermopile by p-n junctions, which sometimes can lead to interference. Between the heaters and the rim, a silicon-aluminum thermopile is integrated in the membrane to measure temperature increase of the sensitive center with respect to the rim. The rim serves as mechanical suspension and as thermal reference.

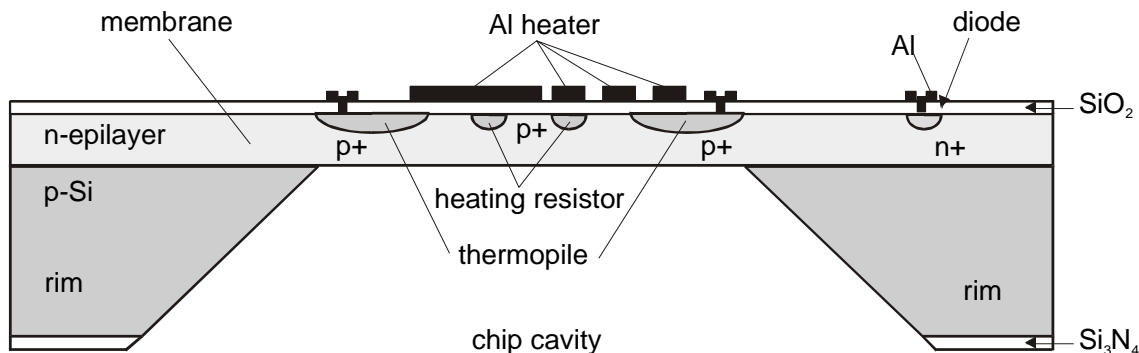

In this way, heat generated by chemical reactions or by biomedical activities in the center of the membrane can be measured with the thermopile (TP+ and TP-, see connections diagram), and the sensor's sensitivity can be calibrated using one of the heaters (Rh, 2 leads for the silicon heater and R1, R2 and R3 for the aluminum heaters). An integrated diode temperature sensor is added on the non-sensitive part of the sensor which allows monitoring of the ambient temperature (indicated as P and N).

The sensor is offered with a *blank sensitive area*, on which catalytic, enzymatic or biomedically active layers can be deposited for testing.

The sensor chip is *encapsulated* in a ceramic Pin-Grid Array (PGA), a 68 pins 11x11 PGA cavity down, with a 11x11 mm square hole in the bottom where the sensor backside is exposed.

Because of the closed membrane, a perfect separation between liquids and electronics can be obtained while maintaining high sensitivity. This is especially convenient for use with flow-injection analysis systems or other liquid systems.

XEN-TCG3880

The thermal conductivity gauge XEN-TCG3880 is a thin-film-thermopile thermal conductivity sensor. It has a separate extended data sheet, please consult this for further details. Typically, the cross section of the XEN-TCG3880 resembles that of the XEN-NCM9924, but the epilayer membrane is replaced by a silicon-nitride membrane, and the thermopile and heater are not in mono-silicon or aluminum, but made out of polysilicon which is on top of the nitride membrane.

5 References

For articles on nanocalorimeters see our website:

www.xensor.nl/index.php/publications

In general for the work of the group of Prof. Schick, see their web site:

<http://www.polymerphysik.uni-rostock.de/>

Conditions: Use of sensors for industrial applications is subjected to patent rights. Xensor Integration assumes no liability arising from violation of these rights

Warranty: Xensor Integration warrants its products against defects in materials and workmanship for 12 months from date of shipment. Products not subject to misuse will be replaced or repaired. The foregoing is in lieu of all other expressed or implied warranties. Xensor Integration reserves the right to make changes to any product herein and assumes no liability arising out of the application or use of any product or circuit described or referenced herein.

Xensor Integration bv

Distributieweg 28
2645 EJ Delfgauw
The Netherlands

Phone +31 (0)15-2578040
Fax +31 (0)15-2578050
Email info@xensor.nl

Founded 18 May 1988
Trade reg. 27227437
Site www.xensor.nl

Smart Sensor Devices

ABN-AMRO 60 50 40 311
IBAN NL42ABNA0605040311
VAT NL 009122746 B01